

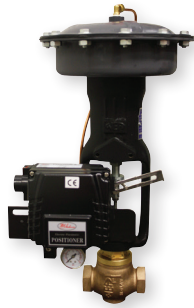

HI-FLOW™ CONTROL VALVES

Globe Valves, Ideal for Steam and Water Flow Control, 1/2" to 2-1/2" Sizes, 2-Way or 3-Way



2-way with positioner



2-way with air-to-close actuator



2-way with air-to-open actuator

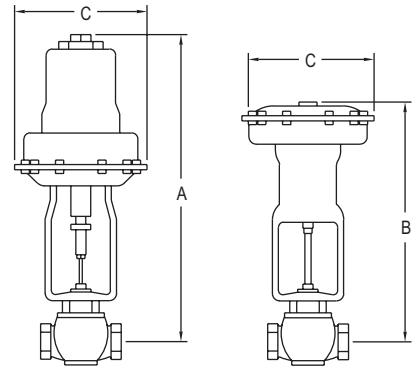

Hi-Flow™ Control Valves are single seated, top or cage guided globe valves - probably the simplest, from a construction standpoint, yet most versatile control valve in use. The Hi-Flow™ valve can fit applications with a smaller size valve since the valve has a greater flow capacity than most conventional valves of the same size. Coupled with the high flow capacity, the Hi-Flow™ valve maintains a wide rangeability of 50:1 to insure precise control. Heavy duty Hi-Flow™ valves are ruggedly constructed of the highest quality materials, precision machined, and performance tested to assure years of trouble free service. Standard packing consists of PTFE V-rings and wiper to minimize friction without leakage at high operating pressures. Available in brass, iron, or 316 SS body, trim is 316 SS with all welded plug construction to provide superior durability and corrosion resistance.

FEATURES/BENEFITS

- Wide rangeability of 50:1
- Exceptional shut-off and leak rate that meets ANSI/FCI 70-2 Class IV (0.01% of Cv in the closed position)
- Selectable fail safe condition with Air-to-Raise or Air-to-Lower actuators and Push-to-Open or Push-to-Close valve bodies
- Linear or equal percentage flow characteristics
- Low flow options of restricted trim or needle plug
- Removable and replaceable seat ring

APPLICATIONS

- Flow control, mixing, or diverting service
- Perfect for steam, water or compatible glycol solutions

HOW TO ORDER

Select model number from model chart or standard product chart and supply maximum upstream pressure, USP.

Use the chart below to aid in the selection of Hi-Flow™ Control Valve. As long as the maximum upstream pressure (USP) is less than, or equal to, the value listed, the model shown can be manufactured and calibrated to your specific requirements. Specify maximum upstream pressure, USP, when ordering.

SPECIFICATIONS

VALVE BODY
Service: Compatible liquids, gases, and steam.
Line Size: 1/2" to 2".
Body Style: 2-way or 3-way globe.
End Connections: 1/2" to 2" female NPT.
Pressure Limit: Iron and bronze body: 250 psi (17.2 bar); 316 SS body: 300 psi (20.7 bar).
Wetted Materials: Body material: Iron, bronze, or 316 SS; Trim: 316 SS.

Packing: PTFE.
Temperature Limits: 20 to 400°F (-7 to 204.4°C).

ACTUATOR
Type: Pneumatic spring/diaphragm.
Control Signal: 3 to 15 psi (0.21 to 1.0 bar) standard. Custom ranges available.
Maximum Supply Pressure: 220, 222, and 230: 100 psi (6.89 bar). 221, 223, 231, and 233: 50 psi (3.45 bar).
Air Connection: 1/4" female NPT.
Temperature Limit: 150°F (66°C).

Note: Positioners and current-to-pressure transducers available factory mounted.

Caution: Use of an actuator supply gas other than air can create a hazardous environment because a small amount of gas continuously vents to atmosphere.

MODEL CHART - CONTROL VALVES - HI-FLOW™ SERIES, 2-WAY, STOCKED MODELS

Pipe Size	Cv 100%	Body Material	Air-To-Open Model	Set at USP psig [bar]	Adjustable USP Range psig [bar]
1/2"	6.45	Bronze	2000VA32-230-QS	125 [8.6]	96-200 [6.8-13.8]
3/4"	10.75	Bronze	2001VA32-230-QS	125 [8.6]	81-155 [5.6-10.7]
1"	17.42	Bronze	2002VA32-230-QS	125 [8.6]	123-166 [8.5-11.5]
1-1/4"	25.30	Bronze	2003VA32-231-QS	125 [8.6]	71-155 [4.9-10.7]
1-1/2"	32.10	Bronze	2004VA32-231-QS	125 [8.6]	66-98 [4.6-6.8]
2"	50.30	Bronze	2005VA32-231-QS	125 [8.6]	121-165 [8.3-11.4]
2-1/2"	50.30	Bronze	2005VA32-233-QS	88 [6.1]	104-137 [7.2-9.5]
2"	50.30	Bronze	2005VA32-233-QS	125 [8.6]	68-88 [4.7-6.1]
2"	50.30	Bronze	2005VA32-233-QS	125 [8.6]	116-145 [8.0-10.0]

MODEL CHART - 2-WAY SIMPLIFIED SELECTION GUIDE WITH STANDARD PRODUCTS

Pipe Size	Cv 100%	Body Material	Air-To-Open Model	Max USP psi [bar] 3-15 [2.1-1.0]	A in [mm]	C in [mm]	Air-To-Close Model	Max USP psi [bar] 3-15 [2.1-1.0]	B in [mm]	C in [mm]
1/2"	6.45	Bronze	2000VA32-230	250 [17.2]	19-3/4 [501.7]	7-3/4 [196.9]	2000VA32-220	250 [17.2]	18-7/16 [468.3]	7-3/4 [196.9]
1/2"	6.45	316 SS	2000VA42-230	300 [20.7]	19-3/4 [501.7]	7-3/4 [196.9]	2000VA42-220	300 [20.7]	18-7/16 [468.3]	7-3/4 [196.9]
3/4"	10.75	Bronze	2001VA32-230	250 [17.2]	19-3/4 [501.7]	7-3/4 [196.9]	2001VA32-220	250 [17.2]	18-7/16 [468.3]	7-3/4 [196.9]
3/4"	10.75	Bronze	2001VA32-231	250 [17.2]	20-3/8 [517.5]	10-5/8 [269.9]	2001VA32-221	250 [17.2]	19-1/8 [485.8]	10-5/8 [269.9]
3/4"	10.75	316 SS	2001VA42-230	285 [19.7]	19-3/4 [501.7]	7-3/4 [196.9]	2001VA42-220	300 [20.7]	18-7/16 [468.3]	7-3/4 [196.9]
3/4"	10.75	316 SS	2001VA42-231	300 [20.7]	20-3/8 [517.5]	10-5/8 [269.9]	2001VA42-221	300 [20.7]	19-1/8 [485.8]	10-5/8 [269.9]
1"	17.42	Bronze	2002VA32-230	166 [11.4]	20-3/16 [512.8]	7-3/4 [196.9]	2002VA32-220	192 [13.2]	18-7/8 [479.4]	7-3/4 [196.9]
1"	17.42	Bronze	2002VA32-231	250 [17.2]	20-13/16 [528.6]	10-5/8 [269.9]	2002VA32-221	250 [17.2]	19-9/16 [496.9]	10-5/8 [269.9]
1"	17.42	316 SS	2002VA42-230	166 [11.4]	20-3/16 [512.8]	7-3/4 [196.9]	2002VA42-220	192 [13.2]	18-7/8 [479.4]	7-3/4 [196.9]
1"	17.42	316 SS	2002VA42-231	300 [20.7]	20-13/16 [528.6]	10-5/8 [269.9]	2002VA42-221	300 [20.7]	19-9/16 [496.9]	10-5/8 [269.9]
1-1/4"	25.30	Bronze	2003VA32-230	98 [6.8]	20-5/16 [515.9]	7-3/4 [196.9]	2003VA32-220	115 [7.9]	19 [482.6]	7-3/4 [196.9]
1-1/4"	25.30	Bronze	2003VA32-231	245 [16.9]	20-15/16 [531.8]	10-5/8 [269.9]	2003VA32-221	250 [17.2]	19-11/16 [500.1]	10-5/8 [269.9]
1-1/4"	25.30	Bronze	2003VA32-233	250 [17.2]	25-13/32 [645.3]	13-3/8 [339.7]	2003VA32-223	250 [17.2]	23-1/8 [587.4]	13-3/8 [339.7]
1-1/4"	25.30	316 SS	2003VA42-230	98 [6.8]	20-5/16 [515.9]	7-3/4 [196.9]	2003VA42-220	115 [7.9]	19 [482.6]	7-3/4 [196.9]
1-1/4"	25.30	316 SS	2003VA42-231	245 [17.0]	20-15/16 [531.8]	10-5/8 [269.9]	2003VA42-221	300 [20.7]	19-11/16 [500.1]	10-5/8 [269.9]
1-1/4"	25.30	316 SS	2003VA42-233	300 [20.7]	25-13/32 [645.3]	13-3/8 [339.7]	2003VA42-223	300 [20.7]	23-1/8 [587.4]	13-3/8 [339.7]
1-1/2"	32.10	Bronze	2004VA32-230	65 [4.5]	20-11/16 [525.5]	7-3/4 [196.9]	2004VA32-220	80 [5.5]	19-3/8 [492.1]	7-3/4 [196.9]
1-1/2"	32.10	Bronze	2004VA32-231	168 [11.6]	21-5/16 [541.3]	10-5/8 [269.9]	2004VA32-221	235 [16.2]	20-1/16 [509.6]	10-5/8 [269.9]
1-1/2"	32.10	Bronze	2004VA32-233	250 [17.2]	25-25/32 [654.8]	13-3/8 [339.7]	2004VA32-223	250 [17.2]	23-1/2 [596.9]	13-3/8 [339.7]
1-1/2"	32.10	316 SS	2004VA42-230	65 [4.5]	20-11/16 [525.5]	7-3/4 [196.9]	2004VA42-220	80 [5.5]	19-3/8 [492.1]	7-3/4 [196.9]
1-1/2"	32.10	316 SS	2004VA42-231	168 [11.6]	21-5/16 [541.3]	10-5/8 [269.9]	2004VA42-221	235 [16.2]	20-1/16 [509.6]	10-5/8 [269.9]
1-1/2"	32.10	316 SS	2004VA42-233	300 [20.7]	25-25/32 [654.8]	13-3/8 [339.7]	2004VA42-223	300 [20.7]	23-1/2 [596.9]	13-3/8 [339.7]
2"	50.30	Bronze	2005VA32-230	31 [2.1]	20-15/16 [531.8]	7-3/4 [196.9]	2005VA32-220	44 [3.0]	19-5/8 [498.5]	7-3/4 [196.9]
2"	50.30	Bronze	2005VA32-231	88 [6.1]	21-9/16 [547.7]	10-5/8 [269.9]	2005VA32-221	140 [9.7]	20-5/16 [515.9]	10-5/8 [269.9]
2"	50.30	Bronze	2005VA42-230	175 [12.1]	26-1/32 [661.2]	13-3/8 [339.7]	2005VA42-223	250 [17.2]	23-3/4 [603.3]	13-3/8 [339.7]
2"	50.30	316 SS	2005VA42-230	31 [2.1]	20-15/16 [531.8]	7-3/4 [196.9]	2005VA42-220	44 [3.0]	19-5/8 [498.5]	7-3/4 [196.9]
2"	50.30	316 SS	2005VA42-231	88 [6.1]	21-9/16 [547.7]	10-5/8 [269.9]	2005VA42-221	140 [9.7]	20-5/16 [515.9]	10-5/8 [269.9]
2"	50.30	316 SS	2005VA42-233	175 [12.1]	26-1/32 [661.2]	13-3/8 [339.7]	2005VA42-223	272 [18.8]	23-3/4 [606.3]	13-3/8 [339.7]

● Transducers: See page 440 (Series 2800)
 See page 441 (Series 2900)
 ● Positioners: See page 442 (Series 1465)
 Filters and Regulators: See page 446

USA: California Proposition 65
 ⚠ WARNING: Cancer and Reproductive Harm - www.P65Warnings.ca.gov

HI-FLOW™ CONTROL VALVE

3-Way Standard Products for Mixing or Diverting

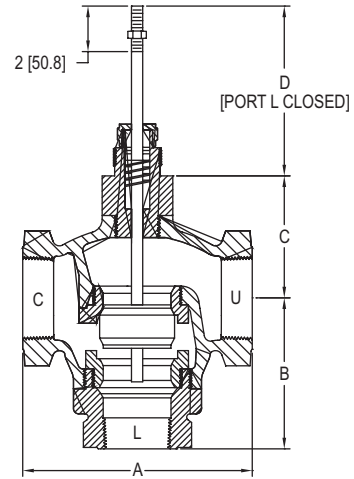
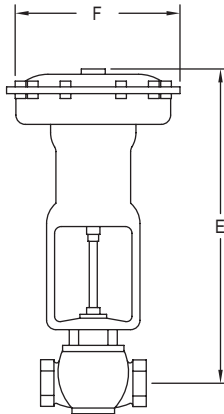

DIMENSIONS			
Pipe Size	B in [mm]	C in [mm]	D in [mm]
1/2"	2-9/16 [65.1]	2-3/16 [55.6]	4-1/8 [104.8]
3/4"	2-9/16 [65.1]	2-3/16 [55.6]	4-1/8 [104.8]
1"	3 [76.2]	2-7/16 [61.9]	4 [101.6]
1-1/4"	3-3/16 [81.0]	2-1/2 [63.5]	3-3/4 [93.3]
1-1/2"	3-3/4 [95.3]	2-3/4 [69.9]	3-11/16 [93.7]
2"	3-15/16 [100.0]	3-3/16 [81.0]	3-11/16 [93.7]

Use the standard models chart to aid in the selection of the most economical Hi-Flow™ 3-Way Control Valve for your application. Standard models include: LIN-E-AIRE® Air-To-Lower Actuator (port L opens on loss of air)

Mixing Service

FLOW IN - ports U&L; FLOW OUT - port C

Specify maximum upstream pressures [USP's]: USP_U and USP_L

To determine shutoff pressure: (USP_U - USP_C) + (USP_L - USP_C)

Diverting Service

FLOW IN - port C; FLOW OUT - ports U&L

Specify maximum upstream pressures [USP's]: USP_C; based on standard 3-15 psi [.21-1.0 bar] pneumatic control signal

To determine shutoff pressure: USP_U + USP_C

MODEL CHART - HI-FLOW™ CONTROL VALVES, 3-WAY SIMPLIFIED SELECTION GUIDE WITH STANDARD PRODUCTS

Pipe Size	Cv 100%	Body Material	Model	USP [S] psi [bar]	E in [mm]	F in [mm]
1/2"	6.45	Bronze	3000WA32-220	250 [17.2]	18-1/16 [458.8]	7-3/4 [196.9]
1/2"	6.45	316 SS	3000WA42-220	300 [20.7]	18-1/16 [458.8]	7-3/4 [196.9]
3/4"	10.75	Bronze	3001WA32-220	250 [17.2]	18-1/16 [458.8]	7-3/4 [196.9]
1"	17.42	Bronze	3002WA32-220	200 [13.8]	18-5/16 [465.1]	7-3/4 [196.9]
1"	17.42	Bronze	3002WA32-221	250 [17.2]	19 [482.6]	10-5/8 [269.9]
1"	17.42	316 SS	3002WA42-220	200 [13.8]	18-5/16 [465.1]	7-3/4 [196.9]
1"	17.42	316 SS	3002WA42-221	300 [20.7]	19 [482.6]	10-5/8 [269.9]
1-1/4"	25.30	Bronze	3003WA32-220	120 [8.4]	18-3/8 [466.7]	7-3/4 [196.9]
1-1/4"	25.30	Bronze	3003WA32-221	250 [17.2]	19-1/16 [484.2]	10-5/8 [269.9]
1-1/4"	25.30	316 SS	3003WA42-220	120 [8.3]	18-3/8 [466.7]	7-3/4 [196.9]
1-1/4"	25.30	316 SS	3003WA42-221	300 [20.7]	19-1/16 [484.2]	10-5/8 [269.9]
1-1/2"	32.10	Bronze	3004WA32-220	80 [5.6]	18-5/8 [473.1]	7-3/4 [196.9]
1-1/2"	32.10	Bronze	3004WA32-221	200 [13.8]	19-5/16 [490.5]	10-5/8 [269.9]
1-1/2"	32.10	Bronze	3004WA32-223	250 [17.2]	21-3/8 [542.9]	13-3/8 [339.7]
1-1/2"	32.10	316 SS	3004WA42-220	80 [5.5]	18-5/8 [473.1]	7-3/4 [196.9]
1-1/2"	32.10	316 SS	3004WA42-221	200 [13.8]	19-5/16 [490.5]	10-5/8 [269.9]
1-1/2"	32.10	316 SS	3004WA42-223	300 [20.7]	21-3/8 [542.9]	13-3/8 [339.7]
2"	50.30	Bronze	3005WA32-220	45 [3.1]	19-1/16 [484.2]	7-3/4 [196.9]
2"	50.30	Bronze	3005WA32-221	100 [6.9]	19-3/4 [501.7]	10-5/8 [269.9]
2"	50.30	Bronze	3005WA32-223	175 [12.1]	21-13/16 [554.0]	13-3/8 [339.7]
2"	50.30	316 SS	3005WA42-220	45 [3.1]	19-1/16 [484.2]	7-3/4 [196.9]
2"	50.30	316 SS	3005WA42-221	100 [6.9]	19-3/4 [501.7]	10-5/8 [269.9]
2"	50.30	316 SS	3005WA42-223	175 [12.1]	21-12/16 [554.0]	13-3/8 [339.7]

Caution: Use of an actuator supply gas other than air can create a hazardous environment because a small amount of gas continuously vents to atmosphere.